

81-QSVM "Quick Stand" Installation Instructions



ONLY WHEN TANK IS EMPTY, remove sprayer from truck as follows:

1. Install rear jack stands into boom center section pipe, one on each side of boom. Extend jack until weight is lifted off rear pivot pins. **DO NOT REMOVE PINS YET!**
2. Tilt sprayer.
3. Install mounting flange to sprayer frame using holes provided in frame.
4. Install front legs on mounting flange and install bolts (provided).
5. Lower sprayer so legs are supporting front of sprayer and cylinder pins are free in their holes. **DO NOT REMOVE PINS YET!**
6. Remove rear pivot pins and jack up rear of sprayer approximately 1 to 2 inches.
7. Unplug hydraulic hoses from truck.
8. Disconnect control cable from console and coil up on back of boom.
9. Drive truck out from under sprayer.

To Install Sprayer on Truck:

1. Back truck under sprayer until rear pivot pinholes are close to rear pivot pinholes on truck.
2. Lower jacks until pin holes line up and pins can be installed.
3. Crank jacks so they are off the floor an inch or so.
4. **RAISE** sprayer enough to raise front stands off floor. Remove bolt and slide stands off frame. Leave flange mount attached to sprayer frame for future use.
5. Lower sprayer and **install front hold down clamps**, reroute wire harness and plug into console.
6. Remove rear jacks and brackets from boom tube.
7. Plug in hydraulic lines and controls.

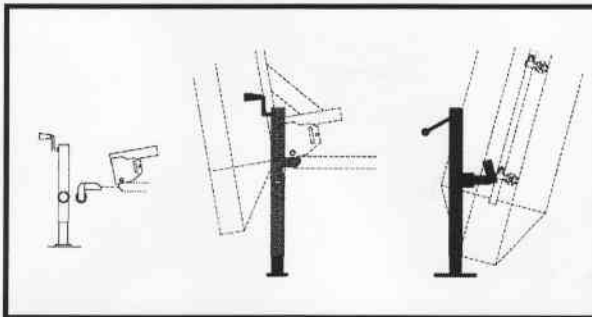

When installing on "Windbreaker 2000" Boom.

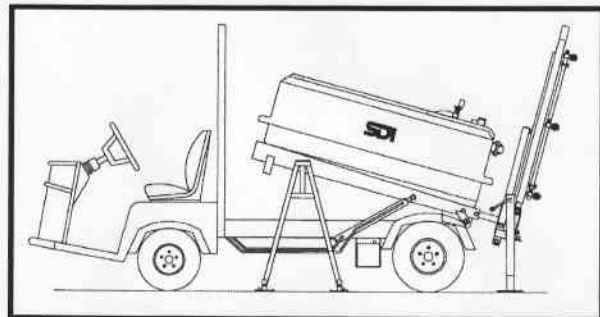

Side view of 81-QSVM.

Insert A

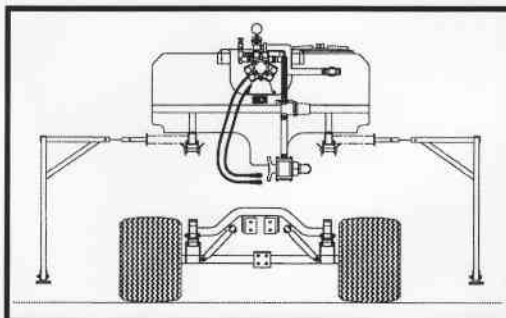

Insert B

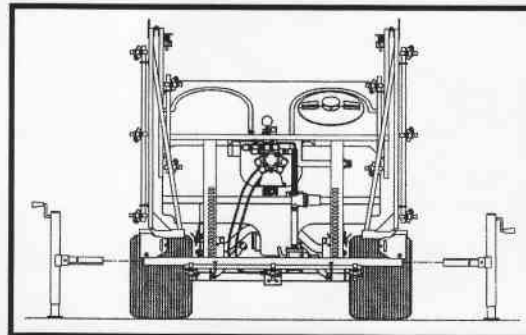

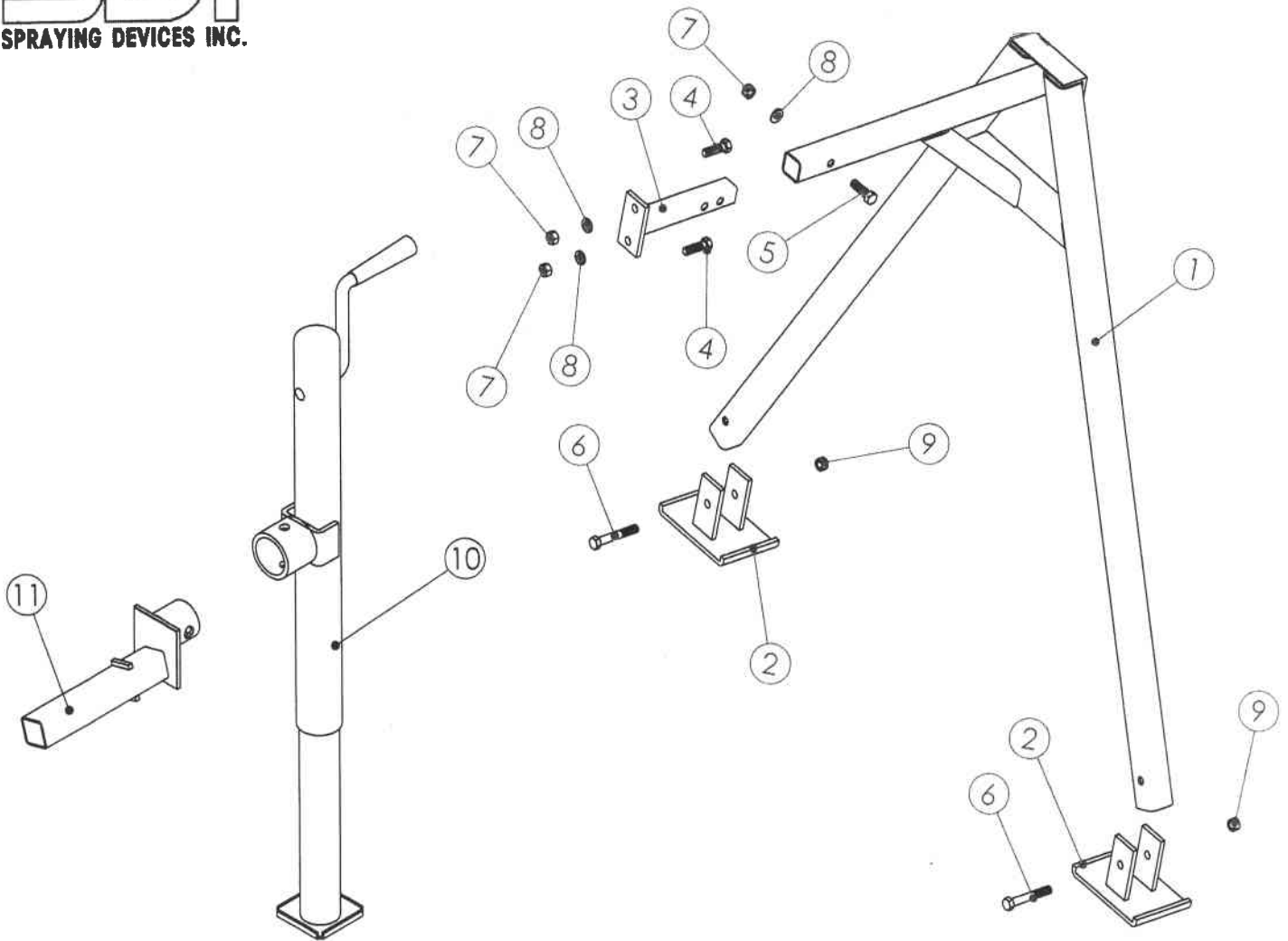

<u>Item No.</u>	<u>Part No.</u>	<u>Description</u>	<u>Qty.</u>
1	11-463	Storage Stand, Side Mount	2
2	11-464	Storage Stand, Foot	4
3	11-476L	Left Frame Attach	1
	11-476R	Right Frame Attach	1
4	32-504	Hex Bolt 3/8 x 1-1/4" SST	4
5	32-506	Hex Bolt 3/8 x 1-3/4" SST	2
6	32-508	Hex Bolt 3/8 x 2-1/4" SST	2
7	41-503	Hex Nut 3/8" SST	6
8	43-503	Lockwasher 3/8" SST	6
9	41-513	Locknut 3/8" SST	4
10	80-208	Jack Stand	2
11	11-469	Boom Mount for Jack Stand	2

SDI Quick Stand
Part No. 81-QSVM