

1125 Series Manual and Electric Hose Reels

Parts Lists and Set-Up Instructions

If your hose reel installation requires drilling into the tank, the tank interior **MUST** be vacuumed and flushed *prior to operation*. Failure to do so will cause clogging of the system's filters and screens.



P. O. Box 3107 • Visalia, CA. 93278-2107
Tel: 559-SDI-5555 • Fax: 559-SDI-5591
email: sales@sprayingdevices.com
www.sprayingdevices.com



Item No.	Part No.	Description	Qty
1	11-401	Gun Holder	1
2	55-212	Male Hose Coupling 1/2"	1
3	24-203	Hose Clamp #JS203	2
4	55-211	Female Hose Coupling 1/2"	1
5	55-106	Adapter 3/4 MPT x 3/4" MGHT	1
6	60-324	Ball Valve 3/4"	1
7	51-501SS	Nipple 3/4" x Clo SST	2
8	50-520SS	Tee 3/4" SST	1
9	81-500	Feed Hose, Per Foot	Specify
10	50-510SS	Street Elbow 90° SST	1
11	55-108	Adapter 1/2 MPT x 3/4" FGHT	1
12	32-504	Bolt 3/8 x 1-1/4" SST	4
13	42-706	3/8" Fender Washer	4
14	41-450	3/8" Well Nut	4

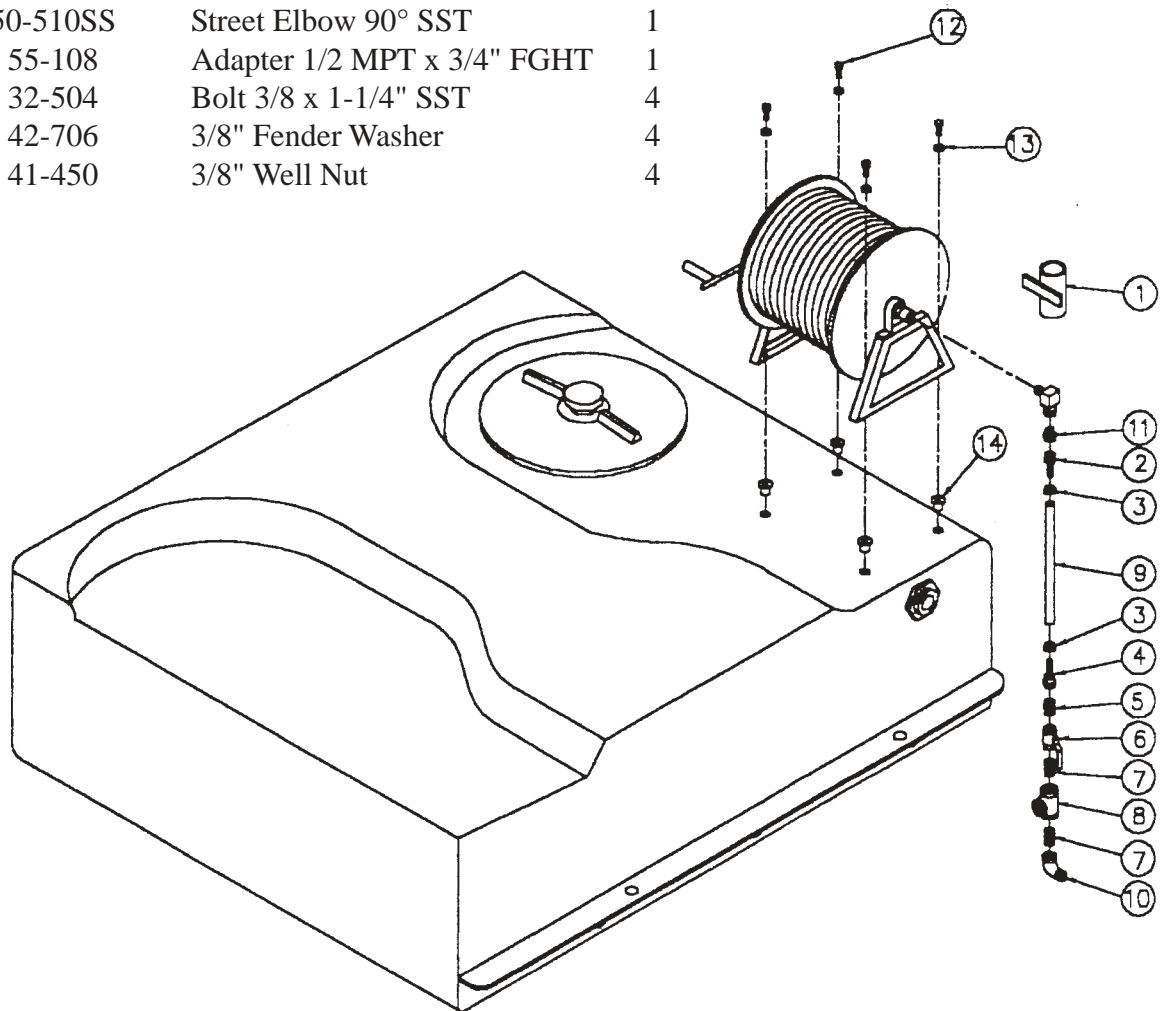

Mounting Instructions:

1. Place the Hose Reel in the desired location on the tank and mark the hole locations.
2. Drill 3/4" holes in tank to match the Hose Reel.
3. Insert the well nut through each hole.
4. After drilling holes in tank, the tank interior **must** be vacuumed and flushed *prior to operation*. Failure to do so will cause clogging of the system's filters and screens.
5. Line up the holes in the Hose Reel base with the holes you have drilled in the tank and bolt into place.
6. Install additional plumbing and connect hose to Hose Reel.
7. Install the Gun Holder in a convenient location.

**SDI Hose Reel Mounting
Instructions - 200 Gallon**

Item No.	Part No.	Description	Qty
1	11-401	Gun Holder	1
2	55-212	Male Hose Coupling 1/2"	1
3	24-203	Hose Clamp Bandit #JS203	2
4	55-211	Female House Coupling 1/2"	1
5	55-106	Adapter 3/4 MPT x 3/4" MGHT	1
6	60-324	Ball Valve 3/4"	1
7	51-501SS	Close Nipple 3/4" SST	2
8	50-520SS	Tee 3/4" SST	1
9	81-500	Feed Hose, Per Foot	Specify
10	50-510SS	Street Elbow 3/4" SST	1
11	55-108	Adapter 3/4 MPT x 3/4" FGHT	1
12	32-504	Bolt 3/8 x 1-1/4" SST	4
13	42-706	Fender Washer 3/8"	4
14	41-450	Well Nut 3/8"	4



Mounting Instructions:

- Place the Hose Reel in the desired location on the tank and mark the hole locations.
- Drill 3/4" holes in tank to match the Hose Reel.
- Insert the well nut through each hole.
- After drilling holes in tank, the tank interior **must** be vacuumed and flushed *prior to operation*. Failure to do so will cause clogging of the system's filters and screens.
- Line up the holes in the Hose Reel base with the holes you have drilled in the tank and bolt into place.
- Install additional plumbing and connect hose to Hose Reel.
- Install the Gun Holder in a convenient location.

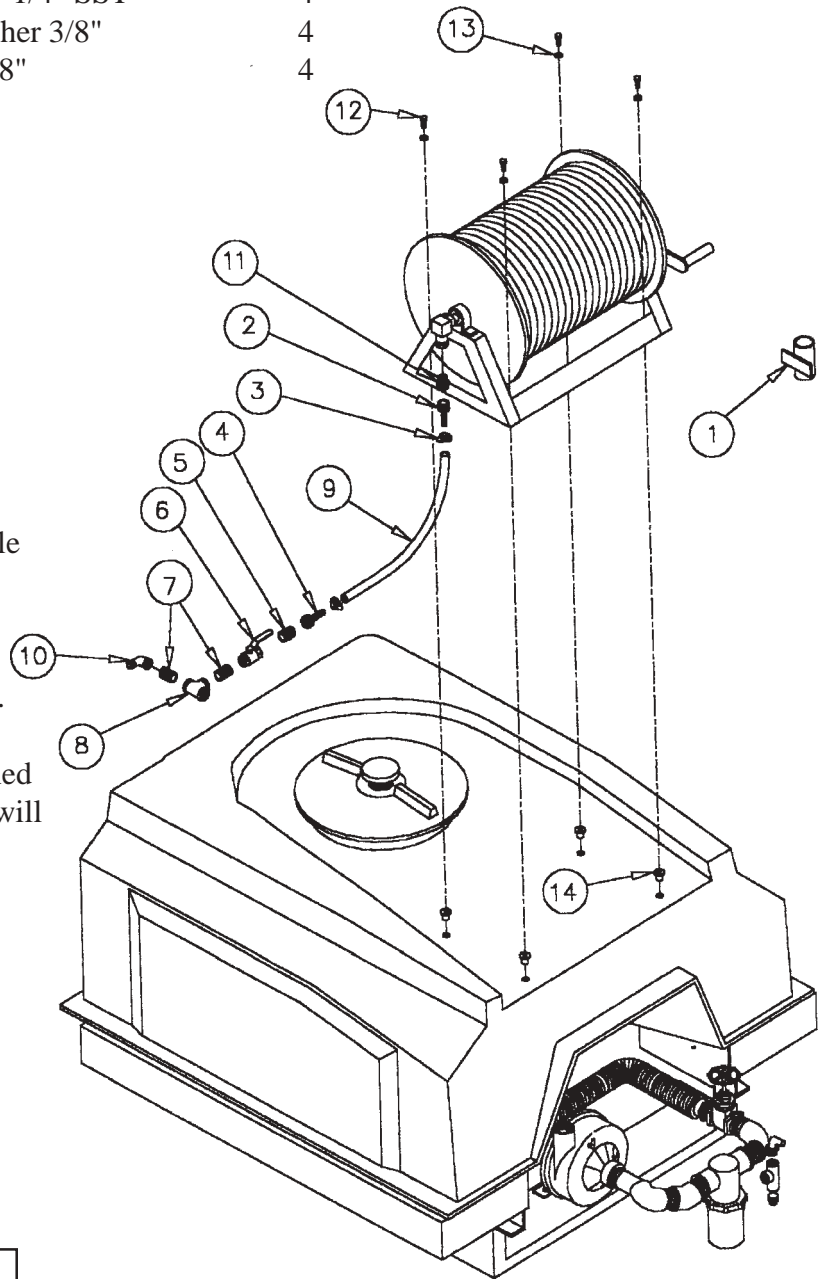

**SDI/Jacobsen Hose Reel
Mounting Instructions -
889895/889896 Hose Reel**

Item No.	Part No.	Description	Qty
1	55-107	Adapter 1/2 MPT x 3/4" FGHT	1
2	55-212	Male Hose Coupling 1/2" HB	1
3	24-203	Hose Clamp Bandit #JS203	2
4	81-500	Feed Hose 1/2" ID, Per Foot	Specify
5	55-211	Female Hose Coupling 1/2" HB	1
6	55-108	Adapter 3/4 MPT x 3/4" MGHT	1
7	60-324	Ball Valve 3/4"	1
8	51-501SS	Close Nipple 3/4", SST	1
9	50-510SS	Street Elbow 3/4", SST	1
10	41-450	Well Nut 3/8" NC	4
11	42-706	Fender Washer 3/8" NC, SST	4
12	32-504	Hex Bolt 3/8 x 1-1/4" NC, SST	4
13	11-401	Gun Holder	1

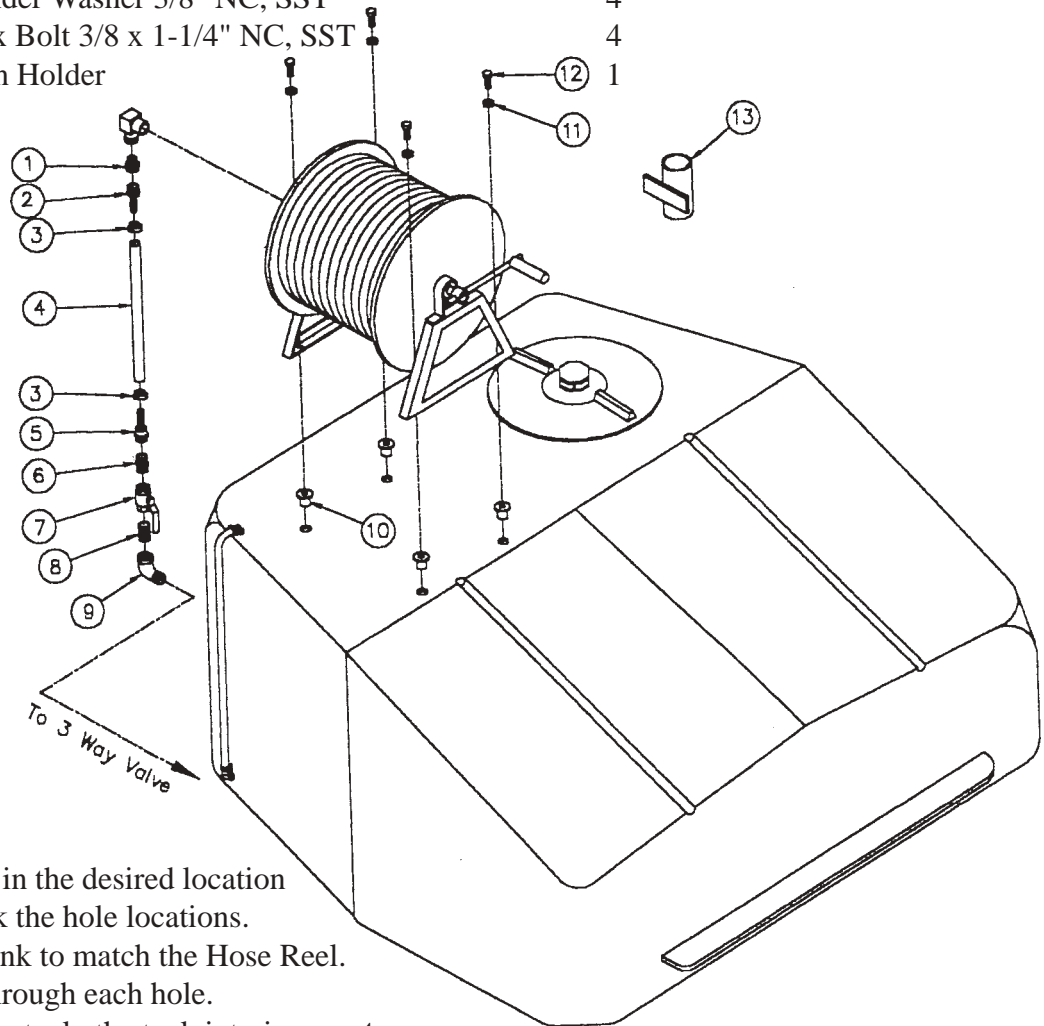

Mounting Instructions:

1. Place the Hose Reel in the desired location on the tank and mark the hole locations.
2. Drill 3/4" holes in tank to match the Hose Reel.
3. Insert the well nut through each hole.
4. After drilling holes in tank, the tank interior **must** be vacuumed and flushed *prior to operation*. Failure to do so will cause clogging of the system's filters and screens.
5. Line up the holes in the Hose Reel base with the holes you have drilled in the tank and bolt into place.
6. Install additional plumbing and connect hose to Hose Reel.
7. Install the Gun Holder in a convenient location.

**SDI/Jacobsen Hose Reel
Mounting Instructions -
DS175 and DS300**

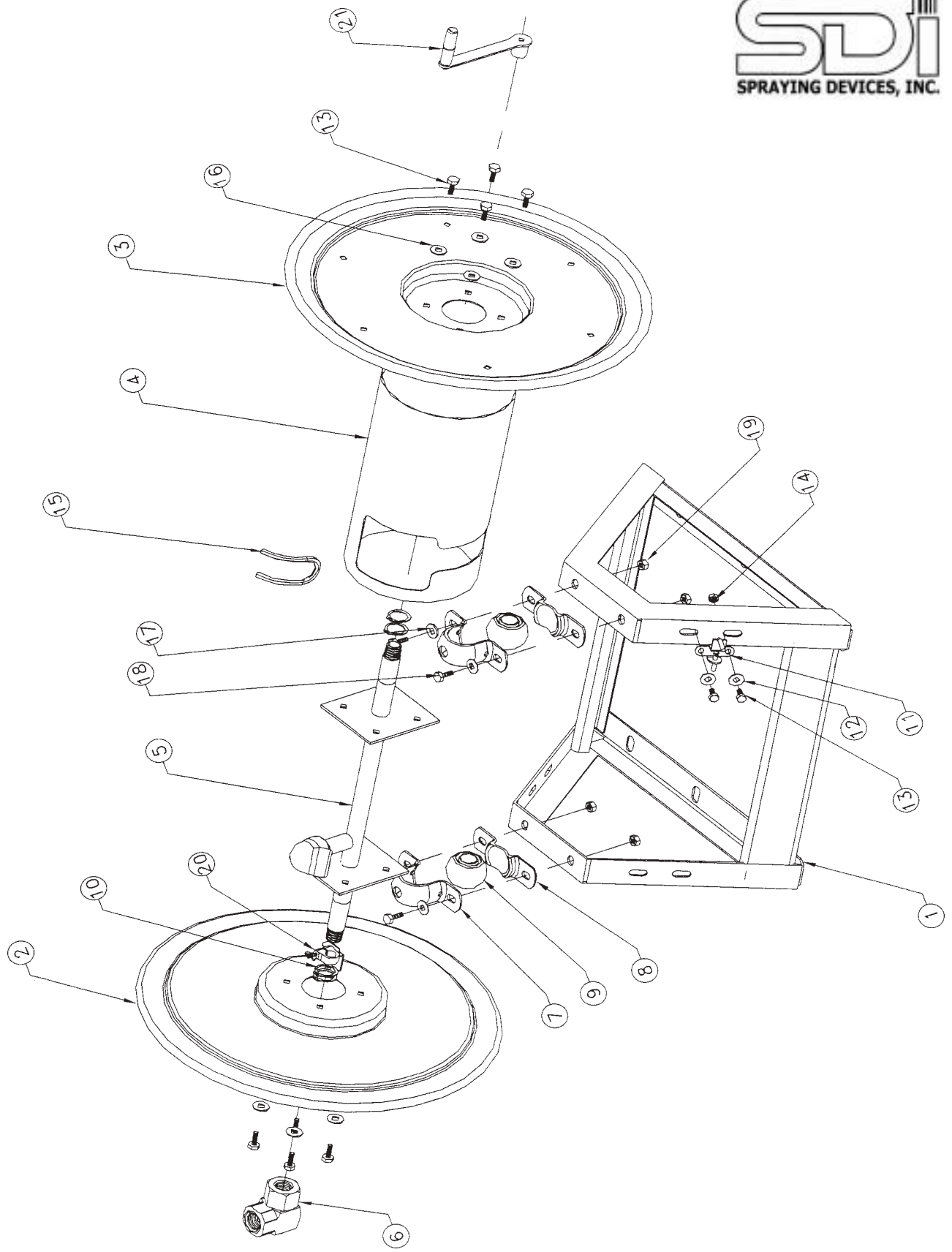

**SDI 1125 Series
 Manual Hose
 Reel**

Manual Hose Reel - 1125 Series

Item Number	Part Number	Description	Qty
1	59-507	Frame 1125-4-100	1
1	59-508	Frame 1125-4-200	1
1	59-509	Frame 1125-4-325	1
2	59-301	Disc SWV Side	1
3	59-300	Disc Crank Side	1
4	59-499	Center Drum 1125-4-100	1
4	59-500	Center Drum 1125-4-200	1
4	59-501	Center Drum 1125-4-325	1
5	59-504	Axle Assembly 1125-4-100	1
5	59-505	Axle Assembly 1125-4-200	1
5	59-506	Axle Assembly 1125-4-325	1
6	59-205	Swivel	1
7	59-228	Top Pillow Block Mounting	2
8	59-229	Bottom Pillow Block Mounting	2
9	59-230	Bearing	2
10	59-232	Retaining Ring	4
11	59-512	Lock Pin Assembly	1
12	59-251	Flatwasher 5/16"	2
13	59-236	Bolt 5/16-18 x 3/4" Long	10
14	59-237	Locking Nut 5/16"	2
15	59-511	Trim, Per Inch	Specify
16	59-240	Lockwasher 5/16"	8
17	59-241	Flatwasher 3/8"	4
18	59-242	Bolt 3/8-16 x 1" Long	4
19	59-243	Locking Nut 3/8"	4
20	59-513	Drag Brake	1
21	59-256	Hand Crank	1

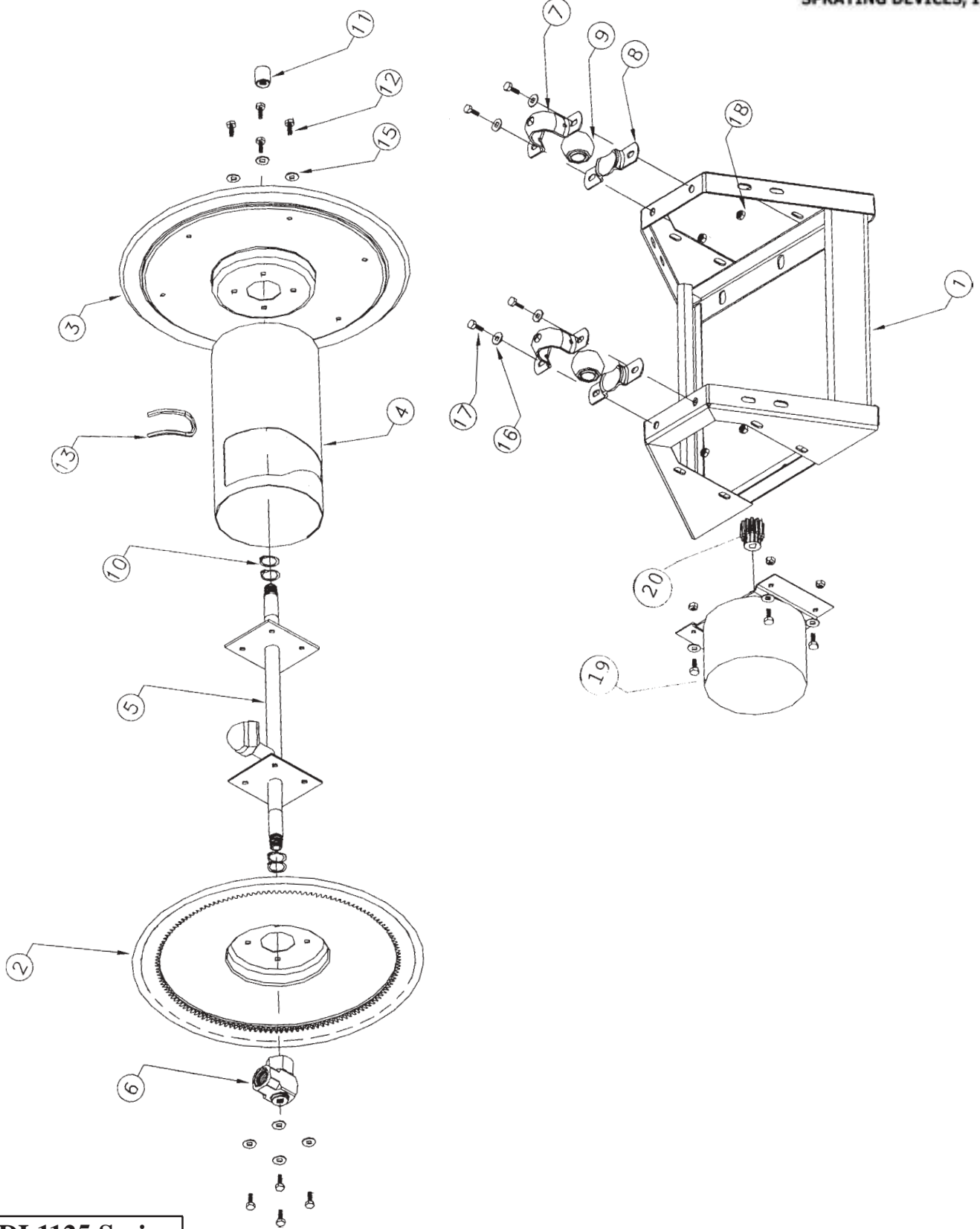

**SDI 1125 Series
 Electric Hose
 Reel**

Electric Hose Reel - 1125 Series

Item Number	Part Number	Description	Qty
1	59-520	Frame 1125-4-100E	1
1	59-521	Frame 1125-4-200E	1
1	59-522	Frame 1125-4-325E	1
2	59-302	Disc W/Gear	1
3	59-300	Disc Crank Side	1
4	59-499	Center Drum 1125-4-100E	1
4	59-500	Center Drum 1125-4-200E	1
4	59-501	Center Drum 1125-4-325E	1
5	59-504	Axle Assembly 1125-4-100E	1
5	59-505	Axle Assembly 1125-4-200E	1
5	59-506	Axle Assembly 1125-4-325E	1
6	59-205	Swivel	1
7	59-228	Top Pillow Block Mounting	2
8	59-229	Bottom Pillow Block Mounting	2
9	59-230	Bearing	2
10	59-232	Retaining Ring	4
11	59-510	Cap	1
12	59-236	Bolt 5/16-18 x 3/4" Long	8
13	59-511	Trim, Per Inch	Specify
15	59-240	Lockwasher 5/16"	8
16	59-241	Flatwasher 3/8"	4
17	59-242	Bolt 3/8-16 x 1" Long	4
18	59-243	Locking Nut 3/8"	4
19	59-247	Motor	1
20	59-305	Pinion	1
21	59-400	Pinion Key/Not Illustrated	1