

# Quick Set-Up Instructions

for

## PG160/PG225/PG300



**Manufacturer of Quality Power Sprayers**

P.O. Box 3107

Visalia, CA 93278-3107 · USA

Tel: (559)SDI-5555 Fax: (559)SDI-5591

[www.sprayingdevices.com](http://www.sprayingdevices.com)

# Table of Contents

|       |   |    |
|-------|---|----|
| I.    | System Requirements   | 1  |
| II.   | Service & Prep ProGator®  | 1  |
| III.  | Remove Utility Box or Any Accessories Mounted<br>to the Rear Chassis Area | 2  |
| IV.   | Uncrate Sprayer   | 2  |
| V.    | Mounting Sprayer to ProGator®   | 2  |
| VI.   | Attaching the Hydraulic Hoses   | 4  |
| VII.  | Spray Booms - Installation  | 6  |
| VIII. | Boom Controls - Installation  | 8  |
| IX.   | Boom Lift - Installation  | 9  |
| x.    | Ground Contour Boom Wheels - Installation                                 | 9  |
| XI.   | Foam Marker - Installation  | 10 |
| XII.  | Hose Reel & Mounting Kit - Installation                                   | 10 |
| XIII. | Additional Miscellaneous Options  | 10 |

## I. System requirements for sprayer use on ProGator®

**A. High output auxiliary hydraulics installed on vehicle (P/N BM20608 for new truck or P/N BM20675 for old truck)**

1. Provides optimum hydraulic performance and cooling while spraying



**B. Speedometer/tachometer (Standard on ProGator®)**



1. Recommended for accurate spraying especially when using motorized boom controls
2. When using computerized flow controls this gives ultimate control and accuracy as well as manual backup in the event of a component failure

**C. Governor or throttle lock installed on vehicle (P/N VGA10298 for new truck or P/N BM19955 for old truck)**

1. Recommended for accurate spraying especially when using motorized boom controls
2. When using computerized flow controls this gives ultimate control and accuracy as well as manual backup in the event of a component failure

## II. Service and prep ProGator®

**A. Check tire pressure**

**B. Check hydraulic fluid level**

**C. Consult the vehicle's manual for recommended service and procedures**

## III. Remove utility box or any accessories mounted to the rear chassis

area

**A. Keep the three attachment pins and hardware for use when mounting the sprayer**



1. Two hinge pins and flip pins

2. One lift cylinder pin, flat washer and flip pin



#### IV. Uncrate sprayer

**A. Remove top portion of shipping crate**



1. Use a reciprocating saw to cut the vertical support boards (do not hit the sprayer with the blade)

**B. Carefully lift the top portion off without hitting or damaging anything**

**C. Remove the strapping and wood blocks from the sprayer frame and base skid**

**D. Move the skid and sprayer to the area with an approved safe lifting device for vehicle mounting**

#### V. Mounting sprayer to ProGator®

**A. Using an approved safe lifting device and methods raise sprayer above shipping skid and discard skid**

**B. Use a 4-point lifting device for best control**

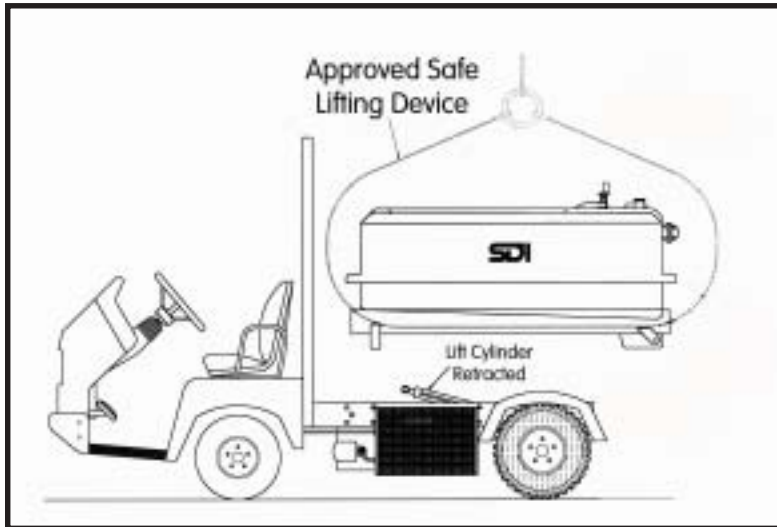

1. If using straps or chains with hook ends be sure to attach the lifting eyebolts to the sprayer's metal frame and not to the fiberglass tank flange
2. Do not forget to compensate for an unbalanced load (a sprayer with or without accessories may be heavier at one end compared to the other)
3. **DO NOT STAND UNDER THE SUSPENDED SPRAYER AT ANY TIME FOR ANY REASON** (personal injury or even Death could occur if the sprayer falls on you or others)

***C. Back the utility vehicle under the raised sprayer and position so the vehicle's rear hinge/pin mounts line up with the same on the sprayer's frame***

1. Set the vehicle's parking brake once you are in position and turn the vehicle off

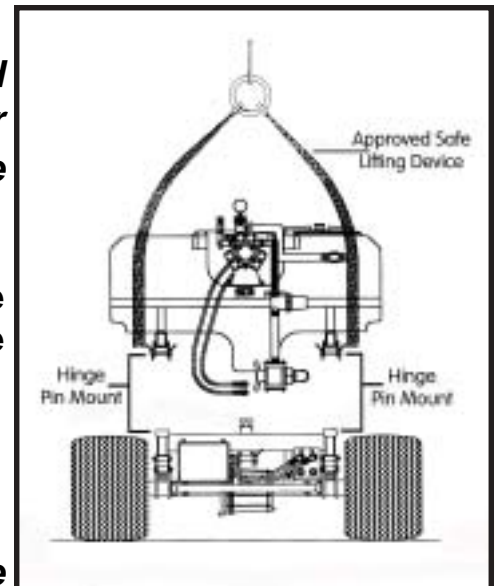

***D. Lower the sprayer carefully onto the vehicle's chassis***

1. Be sure to keep all hoses and wires clear from the frame to eliminate any pinch damage
2. Insert the left and right hinge pins and secure with the flip pins
3. Remove the rear lifting straps and reposition to the front of the sprayer with the front lifting straps

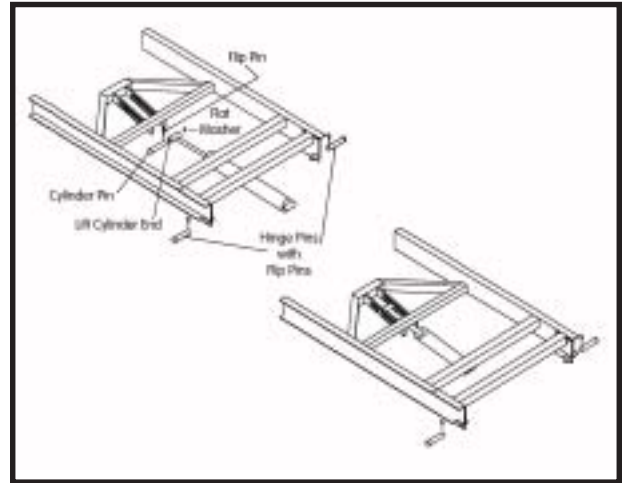
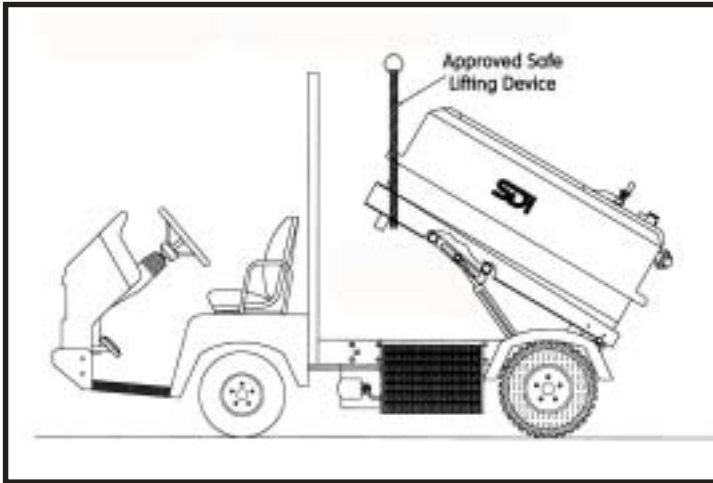

**4. Carefully lift the front of the sprayer until there is enough clearance to raise the center lift cylinder by hand and attach the end to the pin mount slot in the sprayer's frame (it may be necessary to extend the lift cylinder's ram to make attachment easier)**

**5. Insert the cylinder pin into the slot on the sprayer frame and through the end of the lift cylinder and through other slot**

**6. Place flat washer onto pin before attaching the flip pin (failure to do so could result in a binding of the lift ram during raising and lowering of the sprayer)**

**7. Once all pins are installed and the flip pins are secured carefully lower the lifting straps until there is adequate slack to remove them from the sprayer safely**

**8. In the future, when raising the sprayer be sure to use the safety support located in the engine compartment (green channel on storage pins next to the cylinder) to prevent accidental lowering when performing any service work**

**9. Start vehicle and use the hydraulic lift control lever to lower the sprayer's front down onto the vehicle's frame and hold until the ram fully retracts and brings the two frames together then release the lever**



**10. Position and tighten the front frame locks to secure the frame together**

### ***E. Attaching the hydraulic hoses***

**1. Locate the two hydraulic hoses at the rear of the sprayer (they are attached to the pump's hydraulic drive motor assembly)**

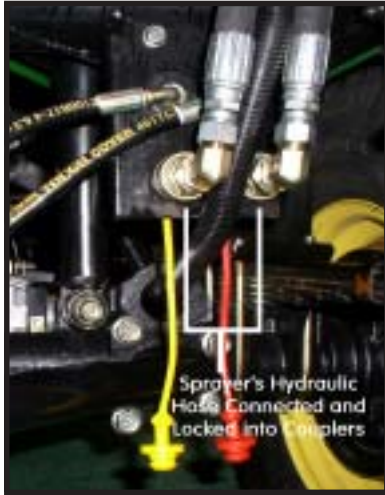

2. Attach the hoses to the two female Auxiliary hydraulics ports on the vehicle's right rear hydraulics panel (should be the lower set of fittings-the top set should have the lift ram hoses attached)
3. The sprayer's hydraulic pump drive can run in either direction so connect the hoses to either port and be sure the locking collars snap back and lock the nipples into the fittings

### ***F. Testing the hydraulic connections***

1. This step can be bypassed until all the accessories have been installed on the sprayer and you are ready to wet test the unit or proceed as follows

2. Locate the bottom load valve below the suction strainer and turn the yellow handle so that the arrow is pointing up at the suction strainer and pump (this allows air to circulate through the pump during the hydraulic test)



3. Set the parking brake and start the vehicle's engine and allow to idle
4. Locate the auxiliary hydraulics on/off lever on the vehicle's center console and pull to turn on

5. The pump should be turning now (you can view the pump shaft turning through the opening on the pump's hydraulic motor coupling flange)

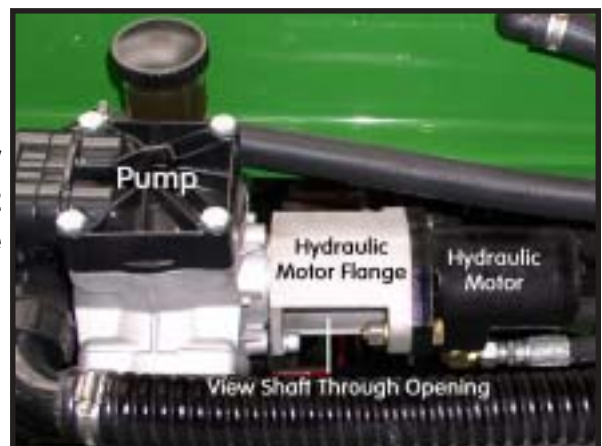



6. If the shaft is not turning, turn the auxiliary hydraulics lever off and recheck the hydraulic hose connections (consult the factory if the problem persists)
7. If pump shaft turns, place auxiliary lever in the off position and proceed to accessories installation

## VI. Spray Booms

### A. Economy Wet Boom- Manual Lift Only (Dealer Assembled)

1. Boom packaged in one box
2. See individual installation sheet

### B. Windbreaker 2000 Shielded Wet Boom Electric Lift (Dealer Assembled)

1. Boom packaged in one crate (partially assembled)
2. See individual installation sheet

### C. Optimum Turf Boom Electric Lift (Factory Assembled Boom)

1. Remove top of shipping crate

a) Use a reciprocating saw to cut the vertical support boards just above the base of the skid (do not hit the boom, nozzles or hoses)



b) Carefully lift the detached top section without damaging any components



2. Locate the completion box containing the boom mounting (T-brackets and hardware)

a) Attach the T-brackets to the rear of the sprayer's frame with the supplied hardware

b) The brackets flat arms mount to the inside of the sprayer's frame and the upright angle mounts must face in towards each other



c) The bolts should be inserted through the frame from the outside and then installed with the lock washer and the nut

d) Tighten all four fasteners securely

3. Attach an approved safe lifting device to the center lift ring on the Optimum Turf Boom's top crossbar



4. Raise the boom up slowly until the approved safe lifting device has the boom suspended above the shipping skid (use caution while raising the boom to the hanging position to avoid damaging the nozzle bodies on the center boom section)



5. Move boom and vehicle together and align the lowest set of slotted holes in the boom's uprights to the lowest holes in the T-brackets



6. Using supplied hardware insert bolts through the brackets from the inside and add the flat washer, lock washer and nut over the upright's slots and properly tighten

7. This will place the boom's nozzles at the maximum height from the ground and insure proper nozzle coverage and overlap

8. The level of the outer wing sections are pre-adjusted at the factory and set with the swag anchor cable assemblies (adjust the eye bolt position to correct any leveling issues)



## VII. Boom Controls

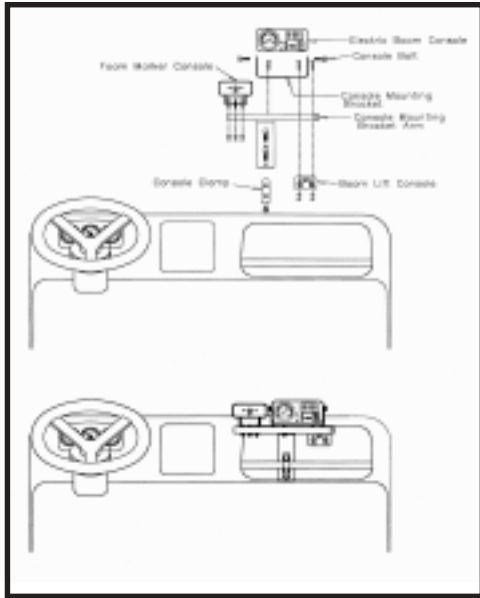

**A. Requires control adapter mounting bracket (P/N 81-415) for attaching the boom and accessory controls to the vehicle's glove box grab rail**

1. Bracket's flat upright mounts behind the grab rail and the lower tab/foot hooks over the rolled edge of the bottom of the glove box and is secured to the rail with the supplied clamp and hardware

2. The bracket may be positioned anywhere along the length of the glove box with the left position providing the easiest operator access

3. See illustration sheet for proper control box locations on the bracket

### **B. Motorized Boom Controls (EC-VM400)**

1. Kit packaged in two boxes

a) **Box 1 contains: Console, harness, power lead, tubing bag and hardware bag**

b) **Box 2 contains: Complete motorized valve assembly, 3/4" hose and hardware bag**

2. See individual installation sheet

### **C. Computerized Boom Controls**

1. Kit packaged in three boxes

- a) **Box 1 contains: console with harness and manual**
- b) **Box 2 contains: Motorized valve assembly, 3/4" poly valve, flow meter, 3/4" hose and hardware bag**
- c) **Box 3 contains: GPS and/or radar speed sensor with cable, adapter power cable, mounting bracket and hardware bag**

**2. See individual installation sheet**

## **VIII. Boom Lift**

### ***A. ELA KIT-2 (Outer Boom Lift for OTB and Windbreaker)***

**1. Kit packaged in two boxes**

- a) **Box 1 contains: switch box and harness assembly**
- b) **Box 2 contains: two actuators and hardware bag**

**2. See individual installation sheet**

### ***B. ELA KIT-1 (Center Lift for Windbreaker)***

**1. Kit packaged in one box**

- a) **Box contains: switch box, harness, one actuator, mounting A-frame and hardware**

**2. See individual installation sheet**

## **IX. Ground Contour Boom Wheels**

### ***A. GC-OTB20***

**1. Kit packaged in one box**

- a) **Box contains: Left and Right wheel assemblies and hardware**

**2. See individual installation sheet**

## **X. Foam Marker**

### **A. 81-FM3 (Quick Foam Marker)**

#### **1. Kit packaged in one box**

a) **Box contains: Mounted Compressor/Solution tank assembly, switch box, power lead, harness, 50' twin line tubing, two foam generator assemblies, 8 oz. bottle (160:1 foam concentrate) and hardware**

#### **2. See individual installation sheet**

## **XI. Hose Reel and Mounting Kit**

### **A. HR200 (Manual Rewind with 200' Fitted 1/2" Fitted Spray Hose)**

#### **1. Reel packaged in one box**

a) **Box contains: Hand crank reel, swivel with 3/4" FGHT fitting and 3/4" MGHT drum outlet fitting and 200' 1/2" fitted spray hose**

### **B. HR200E (Electric Rewind with 200'**

#### **1. Reel packaged in one box**

a) **Box contains: Power rewind reel with 1/3 HP 12-volt DC motor, swivel with 3/4" FGHT fitting and 3/4" MGHT drum outlet fitting, 200' fitted 1/2" spray hose**

### **C. 81-134A (Tank Top Reel Mount Kit)**

#### **1. Kit packaged in one box**

a) **Box contains: (4) rubber well nuts, 3/4" ball valve, 1/2" fitted feed hose, gun holder tube and plumbing/hardware bag**

#### **2. Located in Hose Reel box when ordered with Reel**

#### **3. See individual installation sheet**

## **XII. Additional Miscellaneous Options**

### **A. See Individual product sheets for information**

Spraying Devices, Inc. / P.O. Box 3107 / Visalia, CA 93278-3107 / (559)SDI-5555 Fax: (559)SDI-5591

e-mail: sales@sprayingdevices.com



P.O. Box 3107  
Visalia, CA 93278-3107 USA  
Tel: (559)SDI-5555 / Fax: (559)SDI-5591  
[www.sprayingdevices.com](http://www.sprayingdevices.com)  
[sales@sprayingdevices.com](mailto:sales@sprayingdevices.com)

*Form: 1913.0210jh*